



SPORT BOAT PILOT DRIVES



CABLE STEERED SOLUTION

- Professional Behind Dash Mounting
- Remote Inboard Mounting Options
- Built-in Rudder Feedback Options

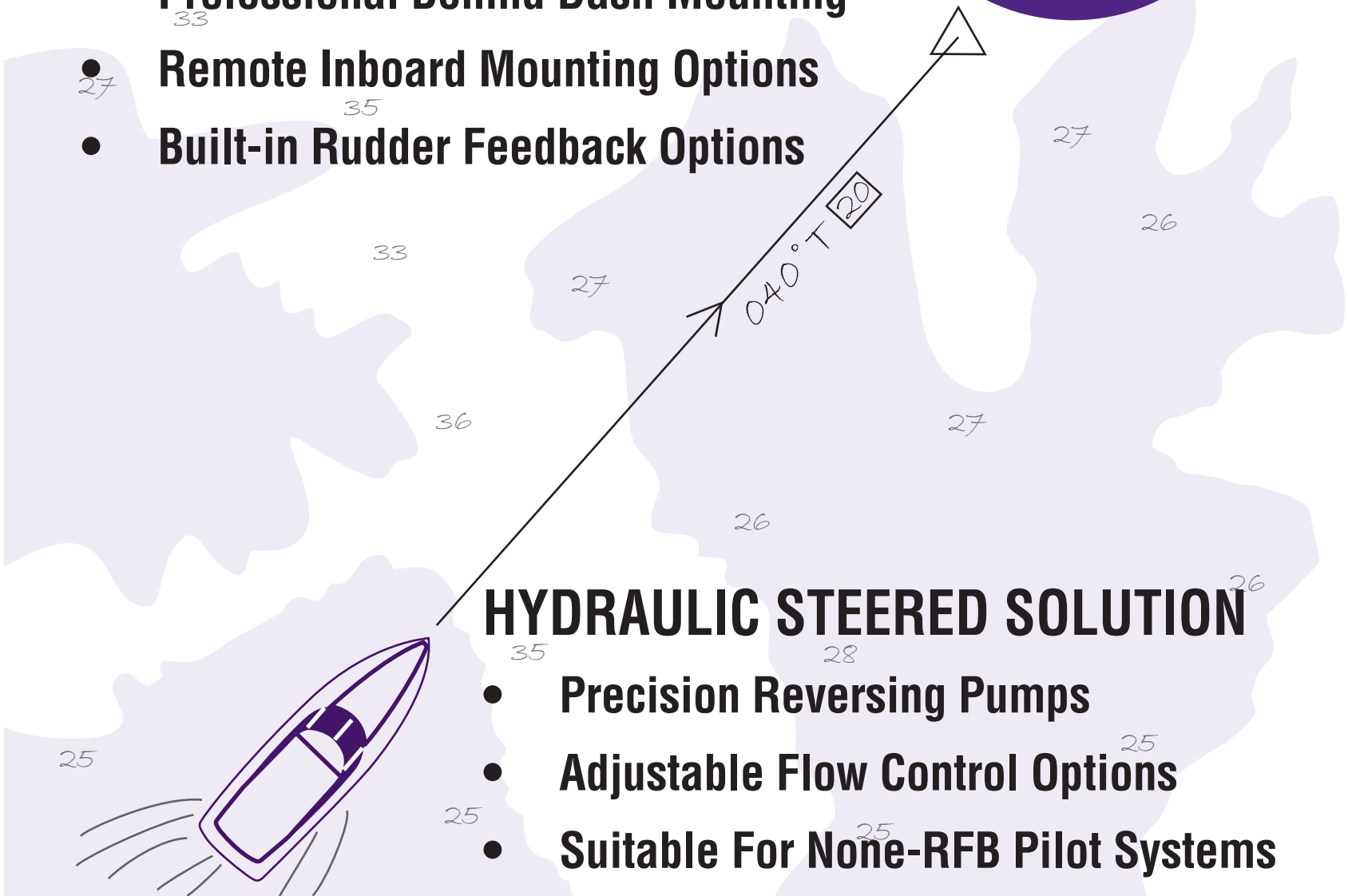

HYDRAULIC STEERED SOLUTION

- Precision Reversing Pumps
- Adjustable Flow Control Options
- Suitable For None-RFB Pilot Systems

***THE PROFESSIONAL OPTION FOR MANUFACTURERS,
DISTRIBUTORS & DEALERS OF AUTOPILOT SYSTEMS***

Hydraulic Steered Solutions

ADJUSTABLE DISPLACEMENT REVERSING PUMP WITH - SHUT OFF VALVE - ¼ SAE PORTS – HOSES

OCTAF101217141	1000cc/min - 12 VOLT (80-280cc CYLINDER)	Peak current 19 Amps	Normal current 6-8 Amps
OCTAF102417141	1000cc/min - 24 VOLT (80-280cc CYLINDER)	Peak current 10 Amps	Normal current 3-4 Amps
OCTAF121217141	1200cc/min - 12 VOLT (100-350cc CYLINDER)	Peak current 19 Amps	Normal current 6-8 Amps
OCTAF122417141	1200cc/min - 24 VOLT (100-350cc CYLINDER)	Peak current 10 Amps	Normal current 3-4 Amps
OCTAF201217141	2000cc/min - 12 VOLT (250cc-460cc CYLINDER)	Peak current 22 Amps	Normal current 7-9 Amps
OCTAF202417141	2000cc/min - 24 VOLT (250cc-460cc CYLINDER)	Peak current 11 Amps	Normal current 4-5 Amps

Cable Steered Solutions

Straight Shaft Dash Mount
Autopilot drive

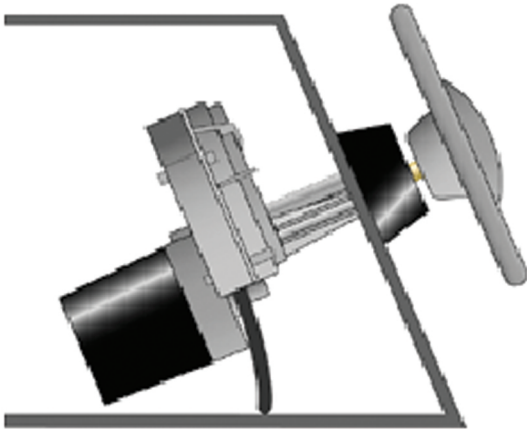

Remote Drive with Stern Drive Connection Kit

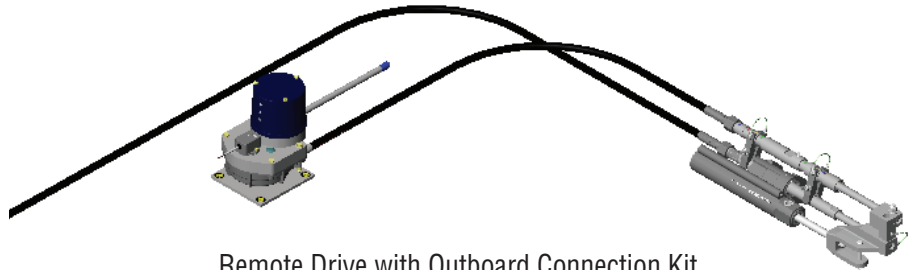

Remote Drive with Outboard Connection Kit

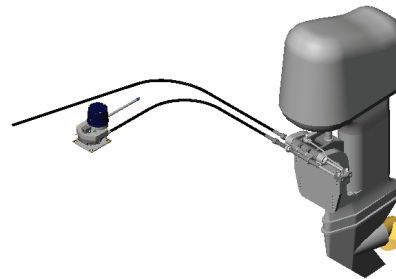

ROTARY MECHANICAL DRIVE UNITS FOR PUSH-PULL CABLE STEERING - 12V ONLY

OCTAFMDMSW	Type 'S' Straight Shaft Behind the Dashboard Drive Unit without Rudder Feed Back (includes 90 degree bezel kit) (Cable adaptors not included)
OCTAFMDTPW	Type 'T' Tilt Shaft Behind the Dashboard Drive Unit without Rudder Feed Back (cable adaptors not included)
OCTAFMDREW	Type 'R' Remote Drive Unit without Rudder Feed Back
OC15SUK06	Rudder Feed Back Potentiometer Module – Universal Kit for all versions of autopilots

ACCESSORIES - REMOTE - ROTARY MECHANICAL DRIVE UNITS

OC15SUK12B	Type B - Multi I/O Connection Kit – Second Steering Cable to Sterndrive Power Steering Cylinder For Mercruiser DHB (from 1994) and Volvo Gas SX & DP-S & Diesel SX drives (from 1997)
OC15SUK12C	Type C - Multi I/O Connection Kit – Second Steering Cable to Sterndrive Power Steering Cylinder For Mercruiser Saginaw (up to 1993) and Volvo Diesel DP drives (from 1994)
OC15SUK15A	Yamaha 115-220 O/B Installation Kit – for Second Steering Cable Connection to Outboard
OC15SUK15B	Mercury-Mariner-Suzuki O/B Installation Kit – for Second Steering Cable Connection to Outboard
OC15SUK19	Universal Connection Kit – for Custom Steering Cable Connection to Tiller or Quadrant
OC15109-6	Standard Steering Cable x 6 foot long – for use with Remote Drive Unit